



3YM30

Configuration	In-line, 4-stroke, vertical, water-cooled diesel engine	
Max. output at crankshaft*	21.3 kW@3200 rpm	[29.1 mhp@3200 rpm]
No. of cylinders	3 cylinder	
Displacement	1.266 L	[77 cu in]
Bore x stroke	80 mm x 84 mm	[3.15 in x 3.31 in]
Aspiration	Natural aspiration	
Combustion system	Indirect injection, in-line pump	
Starting system	Electric starting 12V - 1.4 kW	
Engine management	Mechanical	
Cooling system	Fresh water cooling with heat exchanger	
Alternator	12V - 125A	
Lubrication system	Enclosed, forced lubricating system	
Engine lube oil specifications	API class: CD or higher, SAE grade: 10W-30 or 15W-40	
Direction of rotation at crankshaft	Counterclockwise (CCW) viewed from stern	
Dry weight without gear	127 kg	[280 lbs]
Engine dimensions† L x W x H	715 x 485 x 545 mm	
Emission compliance	EU: RCD 2, BSO II, EMC	US: EPA Tier 3, EPA-C
Flywheel housing size	SAE #6	
Controls	Mechanical	

NOTE:Fuel condition: Density at 15°C = 0.84 g/cm³; 1 kW = 1.3596 mhp = 1.3410 HP

Technical data is according to (ISO 8665) / (ISO 3046)

* Fuel temperature 40°C at the inlet of the fuel injection pump (ISO 8665)

†Length includes KM2P-1 marine gear & height includes U-type elbow (Dimensions may vary with other gears/elbow)

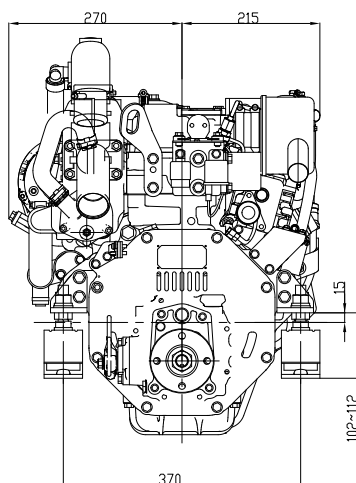
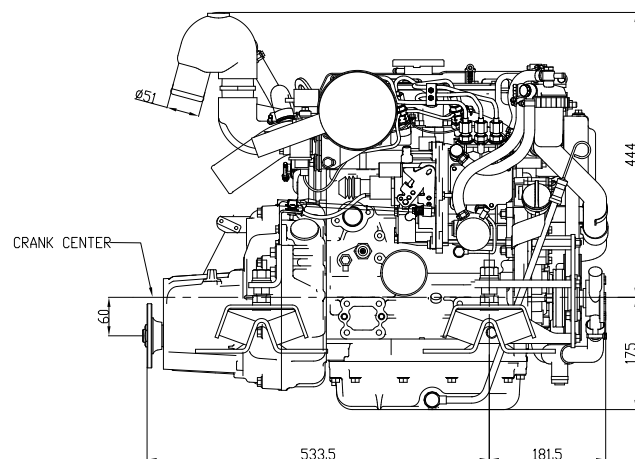
DIMENSIONS**Rear view****Right side view**3YM30AE with KM2P-1 marine gear
(Not to be used for engine installation)



PERFORMANCE CURVES

3YM30 Torque curve

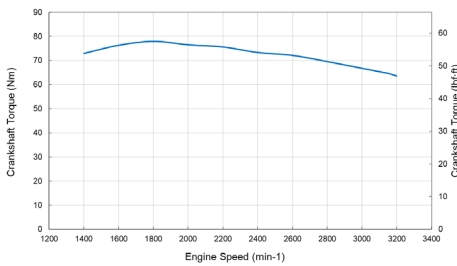

3YM30 Output Power curve

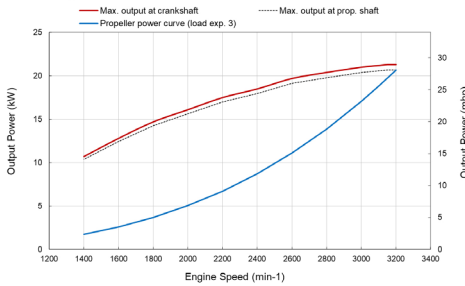

3YM30 Fuel consumption (propload exp 3.0)

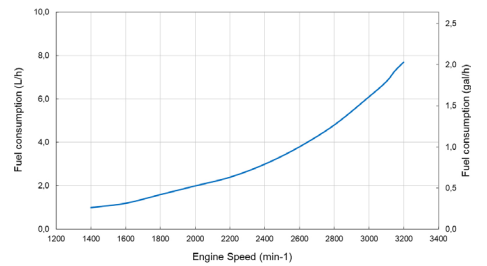

MARINE GEAR / DRIVE*

Model	KM2P-1		Saildrive [SD25]
Clutch type	Mechanical cone clutch		Constant mesh gear with dog clutch
Dry weight	9.8 kg [22 lbs]		30 kg [66 lbs]
Reduction ratio [fwd/asn]	2.21/3.06	2.62/3.06	3.22/3.06
Direction of rotation [viewed from stern]	Clockwise		Counterclockwise
Lubrication system	Splash lubrication		Splash lubrication
Lube oil specifications	API class: CD or higher, SAE grade: #20 or #30		API class: CC or higher, SAE grade: 10W-30
Max. lube oil capacity	0.3 L		2.2
Dry weight - engine & gear/drive	137 kg [302 lbs]		157 kg [346 lbs]

* Other marine gearboxes and configurations available upon request. Contact your local supplier for more information

INSTRUMENT PANELS

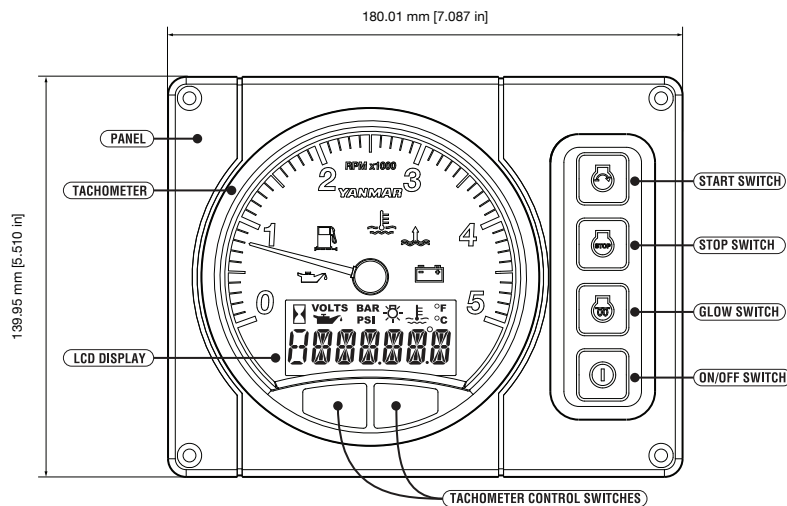

B20 panel

ACCESSORIES

Standard engine package

- Exhaust mixing elbow [L-type]
- Alternator 12V - 125A
- B20 panel
- Flexible mounts
- Expansion tank for fresh water cooling system
- Electric stop solenoid
- Belt safety cover

Optional accessories

- High-riser mixing elbow [instead of L-elbow]
- Extension wire harness [4m, 6m]
- Dual harness [for 2nd station]
- TFX Sidemount control head
- Hot water kit with cocks
- Extension saildrive leg [50 mm]
- Propeller cone nut kit SD25
- On-board spare parts kit

NOTE: All data subject to change without notice. Text and illustrations are not binding.