

N4.40

SPECIFICATIONS

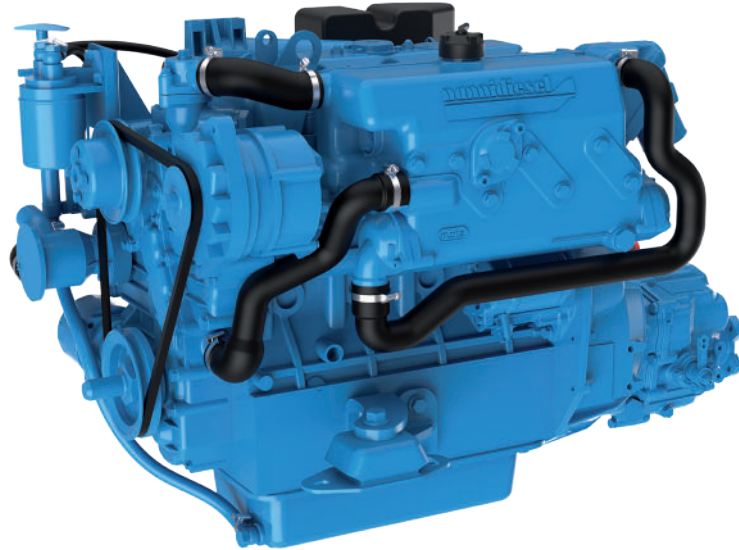

Power at crankshaft	29.4 kW [40 hp]	Engine base	Kubota
Displacement	1.999 l [122 in ³]	Fuel system	Mechanical Indirect injection
Configuration	4 cylinders in line	Air intake	Natural
Operation type	4 strokes Diesel	Cooling	Closed cooling with heat exchanger
Bore & Stroke	83 x 92.4 mm [3.27 x 3.64 in]	Max mounting angle	15° Front down 15° Front up
Compression ratio	22.8 : 1	Alternator	12 Volt 120 Amp
Rated speed	2800 rpm	Rating	M4
Idling speed	850 rpm	Emission compliance	RCD 2013/53/EU EPA marine Tier 3
Peak torque	110 Nm	Dry weight	
Peak torque speed	2000 rpm	with TTMC35A	227 kg [500 lbs]
		with Sail Drive SP60	259 kg [570 lbs]

N4.40

29.4 kW [40 hp] at 2800 rpm

TECHNICAL DESCRIPTION

ENGINE BLOCK

- 4 Cylinders in line
- Gear-driven valve train
- Water cooled exhaust manifold

FUEL SYSTEM

- Mechanical governor
- Cam driven in-line injection pump
- Fuel feed pump with hand primer
- Fuel filter

LUBRICATION SYSTEM

- Replaceable full-flow oil filter
- Oil dipstick
- Oil cooler

COOLING SYSTEM

- Closed cooling with heat exchanger
- Gear driven self-priming raw water pump
- Coolant circulating pump
- Water cooled exhaust elbow

ELECTRICAL SYSTEM & INSTRUMENTATION

- 12 V Electrical system
- 12 V / 120 A alternator
- Electric starter motor
- Electric stop function
- Instrumentation panel, including Start/ Stop, tachometer & alarms
- Extension cable harness with plug-and-play

AIR INTAKE

- Mounted air cleaner

OTHER FEATURES

- Flexible engine mounting
- Bracket for control cables

OPTIONAL EQUIPMENTS & ACCESSORIES

- Keel cooling adaptation
- Complete marine propulsion systems
- Throttle and shift controls
- Additional instrumentation, Flying bridge extension harness
- Polyester frame (Sail Drive version)
- Engine mounting adaptation
- Two pole electrical system
- Water boiler systems
- Stuffing box connections
- Complete fuel systems
- Complete exhaust systems
- SOLAS approved version

RATINGS

- Up to 3000 annual operating hours
- Load factor up to 40%
- Full power for no more than 1 hour out of each 12 hours of operation. The remaining time must be at, or below cruising speed

TRANSMISSIONS

SHAFT LINE

- TM345A - TM345H
- TMC260
- TMC60
- TTMC35A - TTMC35P
- ZF25

SAIL DRIVE

- Sail Drive SP60
- Contact your Nanni representative for more details and availability about transmissions types and models range.

PERFORMANCE CURVES

POWER AT CRANKSHAFT

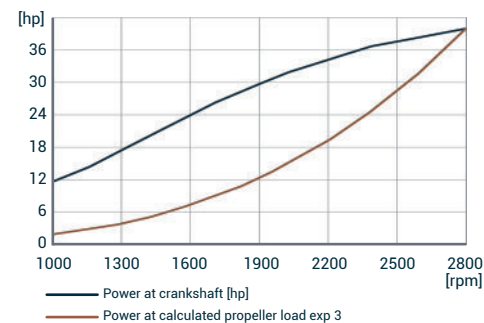

TORQUE AT CRANKSHAFT

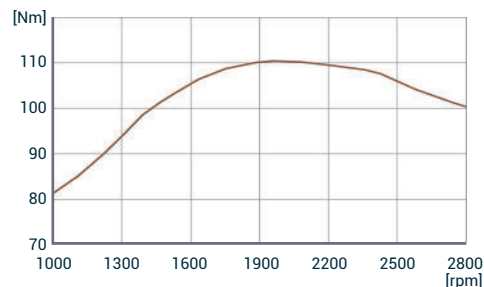

FUEL CONSUMPTION

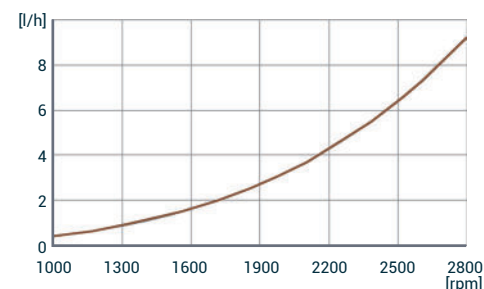

DIMENSIONS AVEC SP60 / TTMC35A

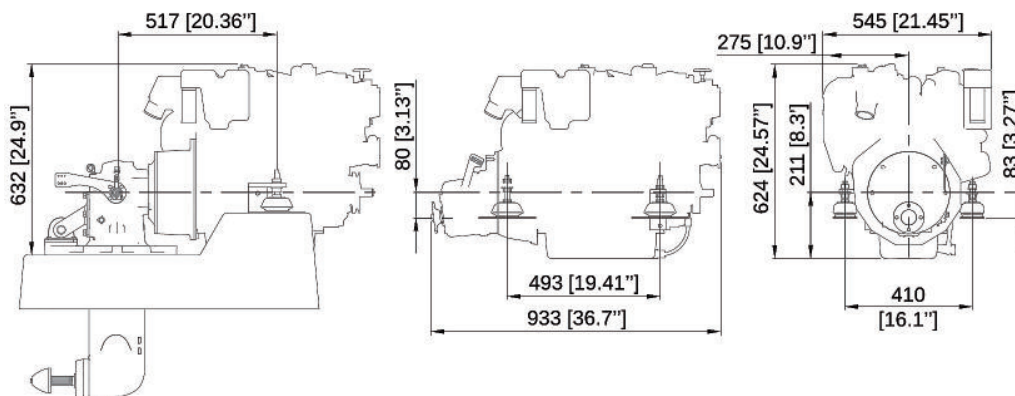

NANNI INDUSTRIES S.A.S.

11, Avenue Abbé Mariotte
33260 La Teste - France
Tel +33 (0)5 56 22 30 60
www.nannienergy.com

NANNI SRL

Via degli Olmetti, 44/A
00060 Formello - Roma - Italia
Tel +39 06 30 88 42 51
www.nannienergy.com

Technical data according to ISO 8665. This document is not contractual. Nanni reserves the right to modify any of the characteristics stated in this document without notice, in a constant effort to improve the quality of its products. Images and illustrations may show non standard equipments. All combination of equipment & accessory are not available.

DGBXXC01006B