

Z6.300

SPECIFICATIONS

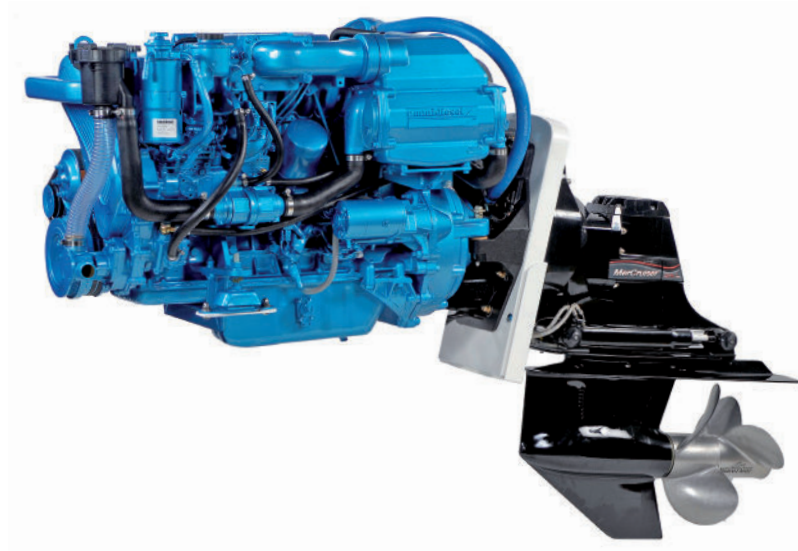

Power at crankshaft	202.4 kW [275 hp]	Engine base	Toyota
Displacement	4.2 l [254 in ³]	Fuel system	Direct injection Mechanical controlled
Configuration	6 cylinders in line	Air intake	Turbocharged with intercooler
Operation type	4 strokes Diesel	Cooling	Closed cooling with heat exchanger
Bore & Stroke	94 x 100 mm [3.7 x 3.94 in]	Max mounting angle	7° Front down 7° Front up
Compression ratio	15.7 : 1	Alternator	12 Volt 80 Amp
Rated speed	3600 rpm	Rating	M6
Idling speed	700 rpm	Emission compliance	RCD 94/25/EC BSO2
Peak torque	687 Nm	Dry weight with Bravo X Three	552 kg [1217 lbs]
Peak torque speed	2400 rpm		

Z6.300

202.4 kW [275 hp] at 3600 rpm

TECHNICAL DESCRIPTION

ENGINE BLOCK

- 6 Cylinders in line
- 4 Valves per cylinder
- Water-cooled exhaust manifold
- Balancing shafts

FUEL SYSTEM

- Direct injection, mechanical controlled
- Mechanically primed fuel filter

LUBRICATION SYSTEM

- Replaceable full-flow oil filter
- Oil dipstick
- Oil cooler

COOLING SYSTEM

- Closed cooling with heat exchanger
- Gear driven self-priming raw water pump
- Coolant circulating pump
- Water cooled exhaust elbow

ELECTRICAL SYSTEM & INSTRUMENTATION

- 12 V / 80 A Alternator
- 12 V starter motor
- Complete instrumentation including key switch and alarms
- Extension cable harness with plug-and-play

AIR INTAKE

- Water-cooled turbocharger
- Intercooler

OTHER FEATURES

- Flexible engine mounting

OPTIONAL EQUIPMENTS & ACCESSORIES

- Complete marine propulsion systems
- Marine transmission adaptation kits
- Throttle and shift controls
- Additional instrumentation, Flying bridge extension harness
- Water boiler systems
- Stuffing box connections
- Complete exhaust systems
- Trolling valve
- Two pole electrical system

RATINGS

- Up to 500 annual operating hours
- Load factor up to 35%
- Full power for no more than 30 minutes out of each 8 hours of operation. The remaining time must be at, or below cruising speed

TRANSMISSIONS

STERN DRIVE

- Bravo X One
- Bravo X Two
- Bravo X Three
- Contact your Nanni representative for more details and availability about transmissions types and models range.

PERFORMANCE CURVES

POWER AT CRANKSHAFT

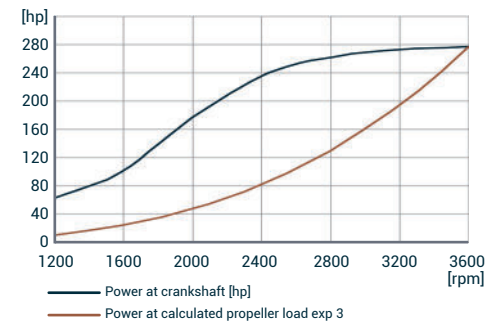

TORQUE AT CRANKSHAFT

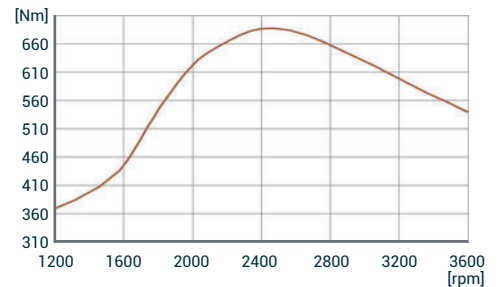

FUEL CONSUMPTION

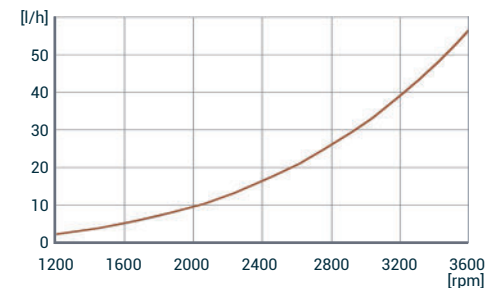

DIMENSIONS WITH BRAVO X THREE

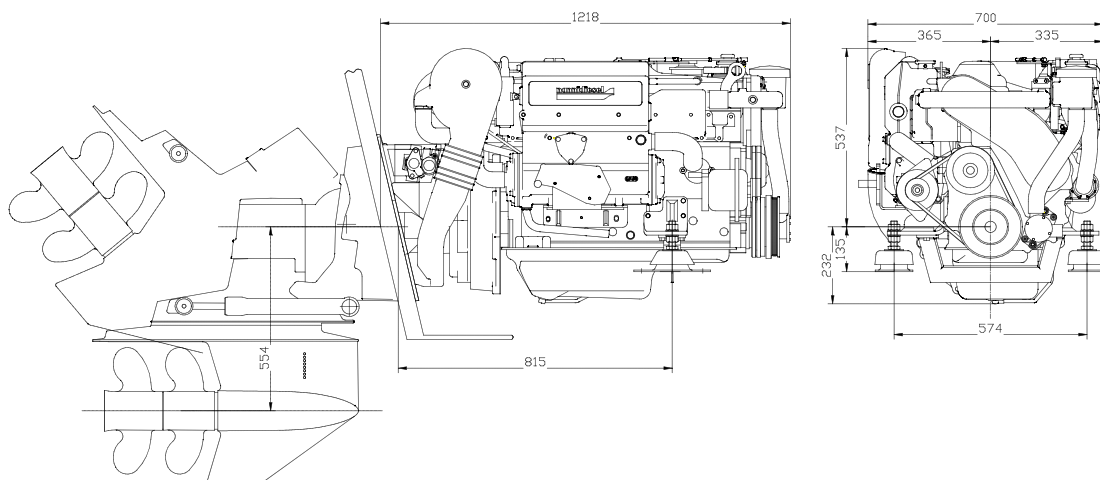

NANNI INDUSTRIES S.A.S.

11, Avenue Mariotte - Zone Industrielle
33260 La Teste - France
Tel: +33 (0)5 56 22 30 60
Fax: +33 (0)5 56 22 30 79

Technical data according to ISO 8665. This document is not contractual. Nanni reserves the right to modify any of the characteristics stated in this document without notice, in a constant effort to improve the quality of its products. Images and illustrations may show non standard equipments. All combination of equipment & accessory are not available.

DGBXXC01021A